

1850 FIXED WINDOW SYSTEMS

PRODUCT TYPES

FLAT FRONT
1" EXTENSION
2" EXTENSION

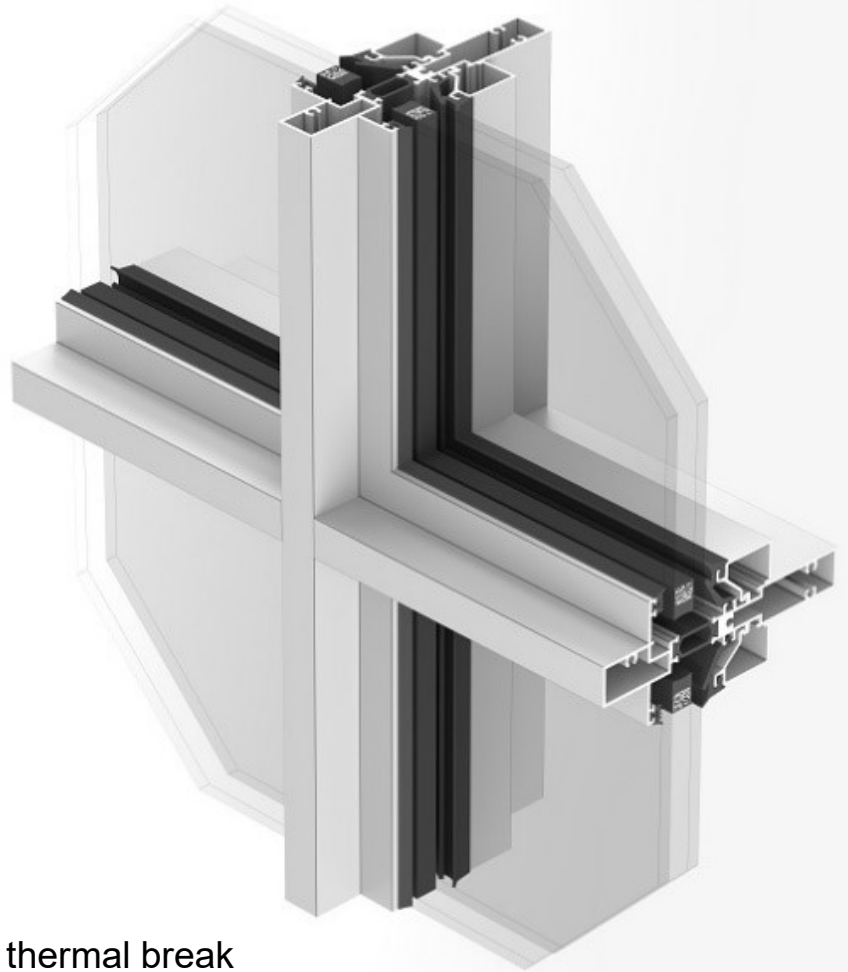

PRODUCT FEATURES

- Slim profile for wider visibility
- High-performance polyamide thermal break
- Interior glazing
- Full rain screen system to allow water go out
- Durable EPDM seal gaskets on exterior and interior
- Easy installed prime air seal
- Setting for either double glazing and triple glazing
- Interconnecting mullion provides solution to fast installation and flexibility in design
- Standard finish in clear anodized and black anodized, options to different colors on exterior and interior
- Flexible to custom design and unlimited integration to standard and/or any sizes of vents

1850 FIXED WINDOW SYSTEMS

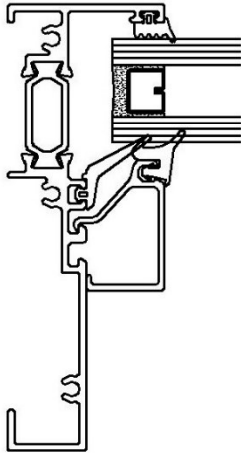

FLAT FRONT

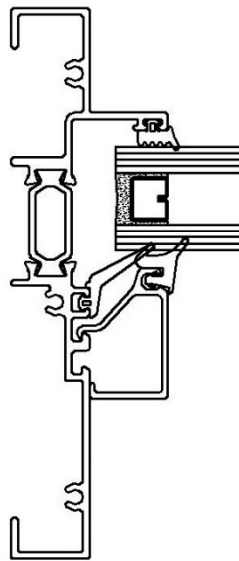

1" EXTENSION

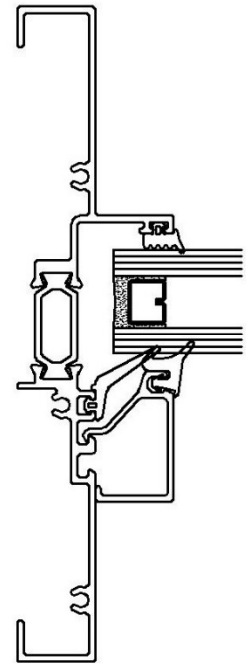

2" EXTENSION

SIZE DETAILS

1850 Fixed Window	Frame Depth	Mullion Sightline	Perimeter/Sill Sightline	Thermal Break Depth	Glass Overall Thickness
Flat Front	108.9mm (4 1/4")	57.2mm (2 1/4")	38.1mm (1 3/4")	26.0mm (1")	Double Glazed 25.4mm (1") Triple Glazed 36.6mm (1 7/16") Triple Glazed 44.5mm (1 3/4")
1" Extension	134.3mm (5 1/4")				
2" Extension	159.7mm (5 1/4")				

PERFORMANCE

Product designation	Air Leakage Resistance	Water Penetration Resistance	Uniform Load Deflection	Uniform Load Structural	Forced-entry Resistance	U-factor
Class CW-PG70	<0.1 L/s/m2 (<0.01 cfm/ft2) @ 75 Pa (1.60 psf)	720 Pa (15.04 psf)	Design 3360 Pa (70.2 psf)	Design: 3360 Pa (70.2 psf) Maximum: 5070 Pa (105.3 psf)	F10 rating	See U-factor Table