



HIGH PERFORMANCE THERMAL TILT AND TURN WINDOW  
ET&T1070



**FRAME**

FRAME DEPTH 70mm (2 ¾")

MIN SINGLE WINDOW WIDTH 483mm (19")

MAX SINGLE WINDOW WIDTH 1000mm (40")

RECOMMEND MAX SINGLE WINDOW WIDTH 813mm (32")

MIN SINGLE WINDOW WIDTH 584mm (23")

MAX SINGLE WINDOW HEIGHT 1980mm (78")

RECOMMEND MAX SINGLE WINDOW WIDTH 1524mm (60")

**GLAZING**

Insulated, Tempered Glass, Low-E, Argon Filled, Warm-Edge Spacer, 3A Molecular Sieve

Thickness Double Glazing 5mm+12mm+5mm  
(OVERALL = 22mm (7/8"))

6mm+12mm+6mm  
(OVERALL = 24mm (1"))

8mm+12mm+8mm  
(OVERALL = 28mm (1-1/8"))

Triple Glazing 5mm+12mm+5mm+12mm+5mm  
(OVERALL = 39mm (1-1/2"))

6mm+12mm+6mm+9mm+6mm  
(OVERALL = 39mm (1-1/2"))

6mm+12mm+6mm+12mm+6mm  
(OVERALL = 42mm (1-5/8"))

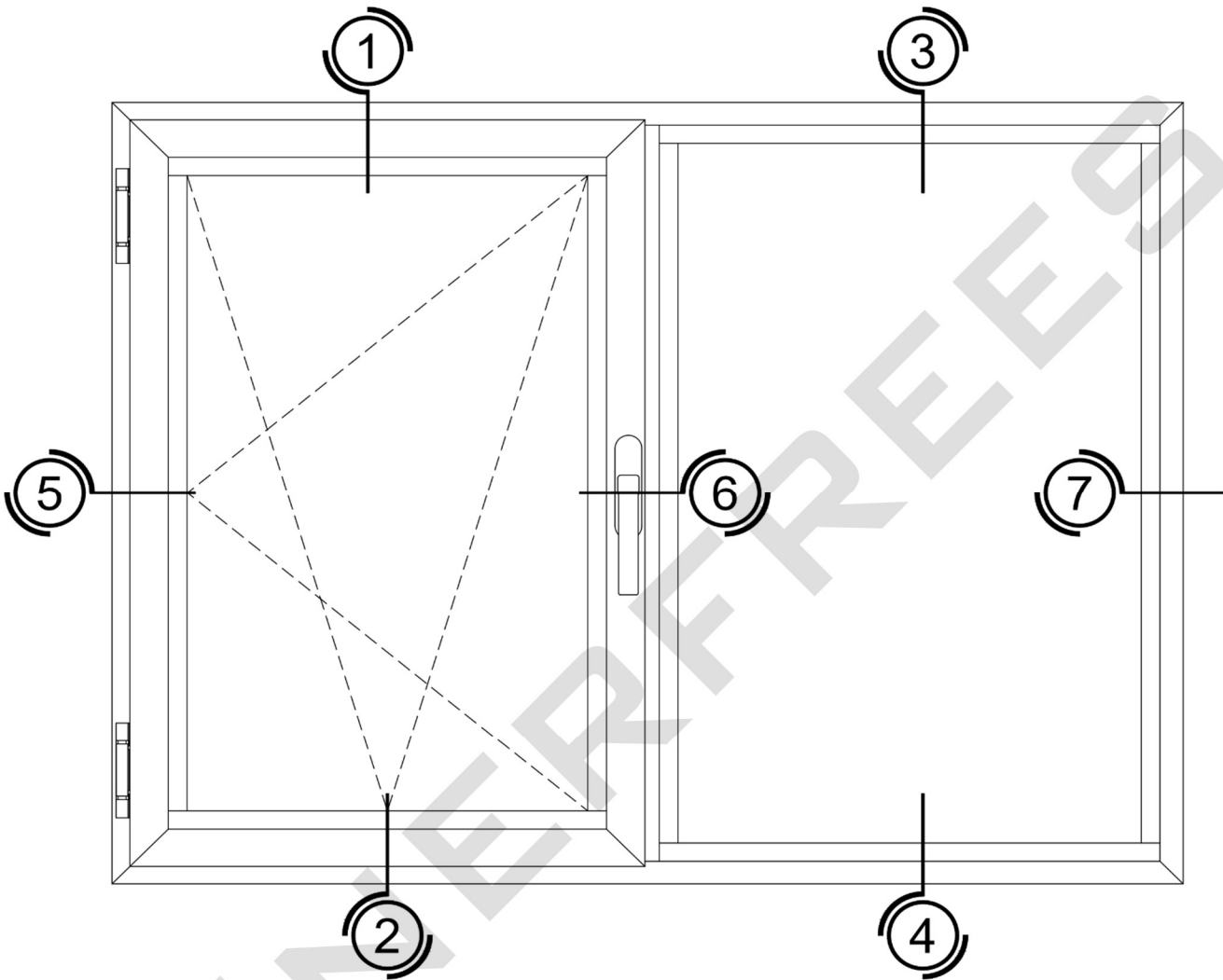



DETAILS:

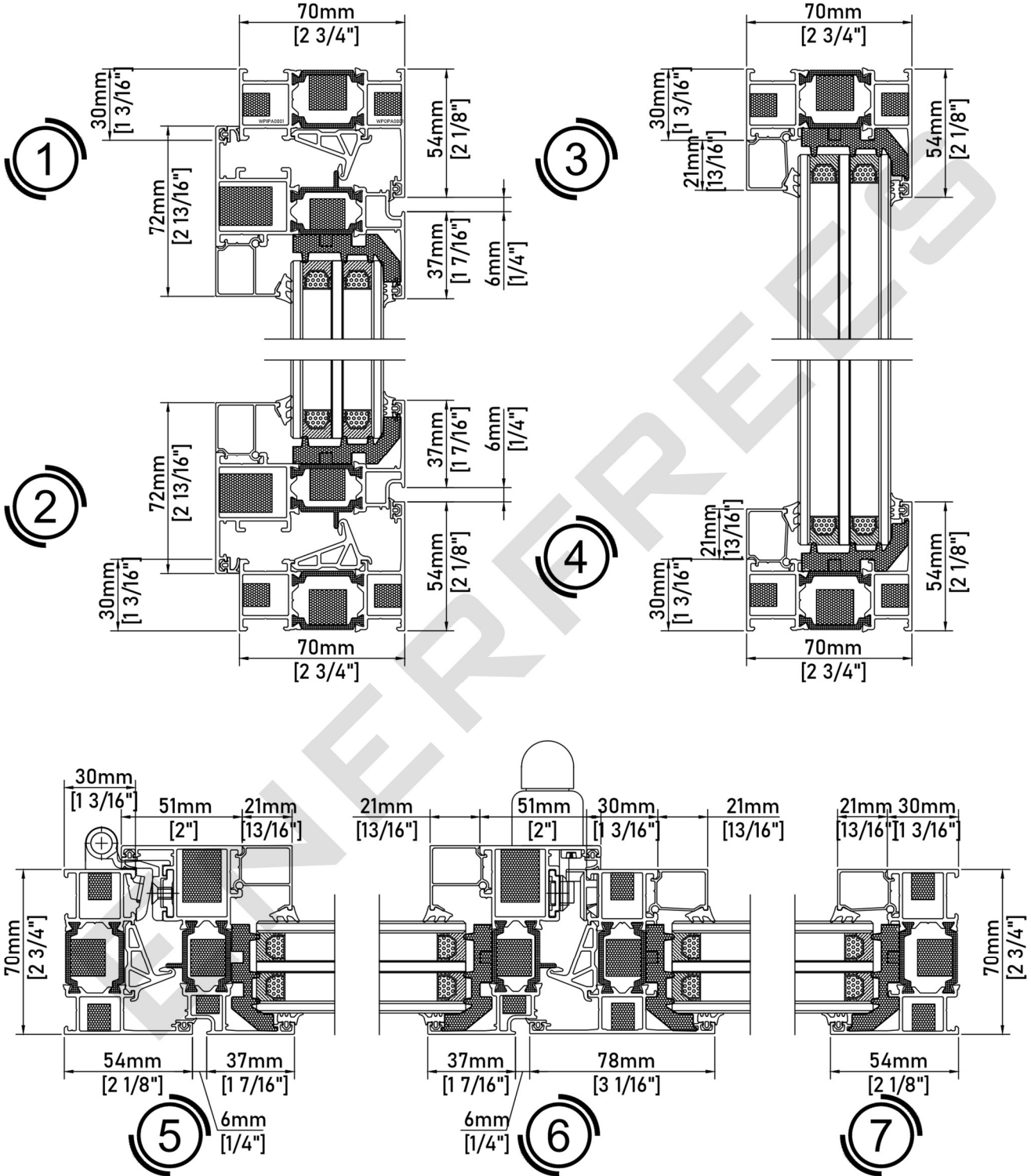



## FENESTRATION

Commonly used in high-rise and mid-rise buildings to meet increased loading requirements and limits on deflection, and in buildings where frequent and extreme use of the fenestration products is expected.

## FINISH

**POWDER COATED.** Powder coating is a polyester based coating that uses uniformly sized micro-beads of polyester, electrostatically charged to adhere to base materials. The coating is thick like an epoxy paint, but because it is electrostatically charged and then baked/cured onto the base material, it doesn't flake or peel like paint or epoxy. The color is softer than comparable colors and the depth of the coating is larger.

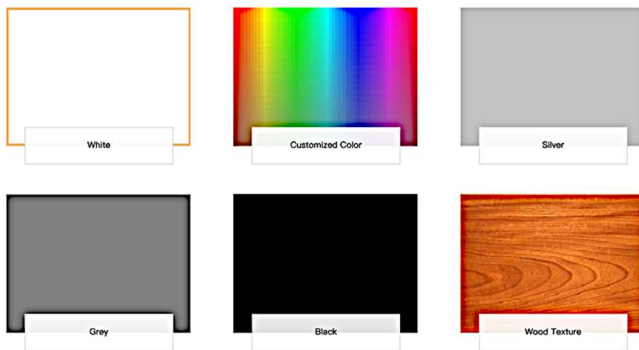

### ADVANTAGE:

- Wide selection of colours
- Texturized finish is an option

## ENERFREES HIGH-PERFORMANCE THERMAL BREAK (PA 66 OR NYLON 66)

Polyamide 66 (PA66) is a type of nylon. PA 66 is made of two monomers each containing 6 carbon atoms, hexamethylenediamine and adipic acid.

Melting point:	268.8 °C
Formula:	(C <sub>12</sub> H <sub>22</sub> N <sub>2</sub> O <sub>2</sub> ) <sub>n</sub>
Density:	1.31 g/cm <sup>3</sup>
Boiling point:	452.1 °C
PubChem CID:	3032893

### General Characteristic:

- High strength and stiffness at high temperature
- Good impact strength, even at low temperature
- Good abrasion and wear resistance
- Good fatigue resistance
- High water absorption and water equilibrium content limits the usage
- Low dimensional stability



**ENERFREES**  
Window & Wall Systems

## TILT AND TURN WINDOW

## S-EF1070

### FRAME DESCRIPTION:

High Performance Thermally broken window system with frame depth of 70mm (2 3/4") frame section.

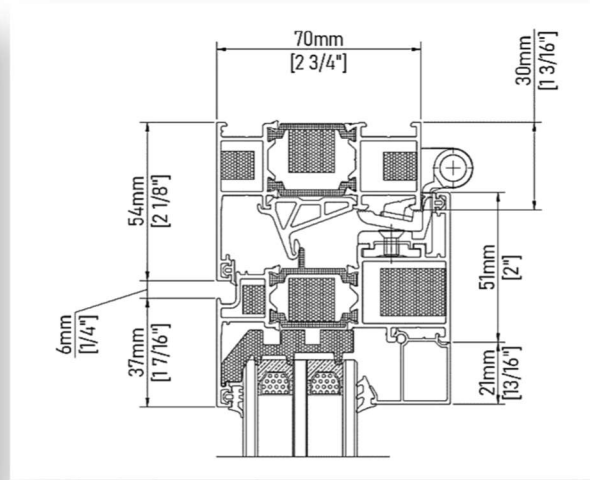
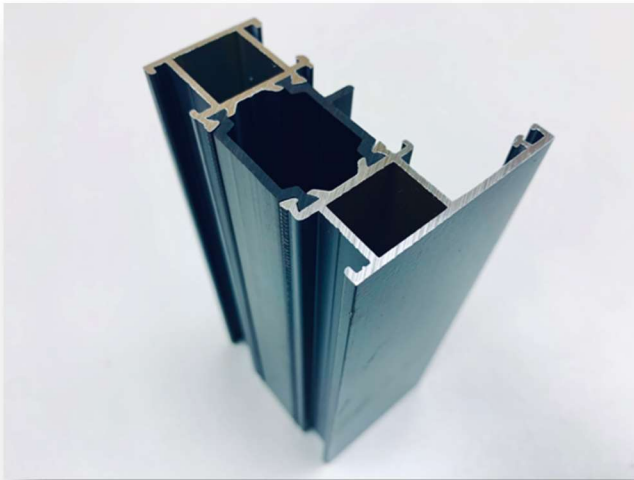

### PARTS AND ACCESSORIES

<p><b>WPPFA0001</b> – PRIME FRAME ASSEMBLY (PFA) 6063-T5</p>	
<p><b>WPOPA0001</b> – OUTSIDE PRIME ALUMINUM (OPA) 6063-T5</p>	
<p><b>WPIPA0001</b> – INSIDE PRIME ALUMINUM (IPA) 6063-T5</p>	



**ENERFREES**  
Window & Wall Systems

## TILT AND TURN WINDOW

## S-EF1070

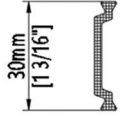
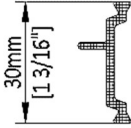
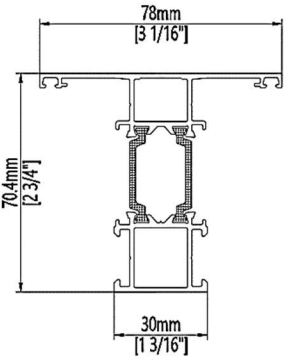
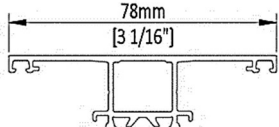
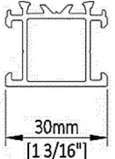
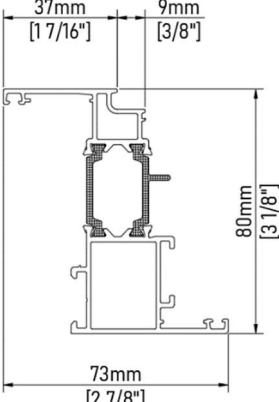
<p><b>WPCTB0001</b> – C THERMAL BREAK (CTB) NYLON 66 (PA66)</p>	
<p><b>WPYTB0001</b> – Y THERMAL BREAK (YTB) NYLON 66 (PA66)</p>	
<p><b>WPMFA0001</b> – MULLION FRAME ASSEMBLY (MFA)</p>	
<p><b>WPOMA0001</b> – OUTSIDE MULLION ALUMINUM (OMA) 6063-T5</p>	
<p><b>WPIMA0001</b> – INSIDE MULLION ALUMINUM (IMA) 6063-T5</p>	
<p><b>WPSFA0001</b> – SASH FRAME ASSEMBLY (SFA)</p>	



**ENERFREES**  
Window & Wall Systems

## TILT AND TURN WINDOW

## S-EF1070

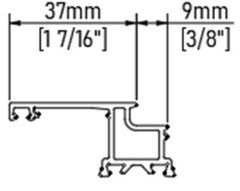
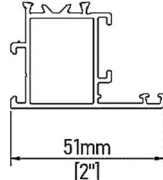
<p><b>WPOSF0001</b> – OUTSIDE SASH FRAME (OSF) 6063-T5</p>	
<p><b>WPISF0001</b> – INSIDE SASH FRAME (ISF) 6063-T5</p>	

### GLASS STOPS

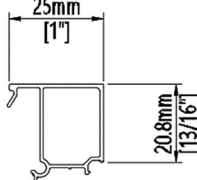
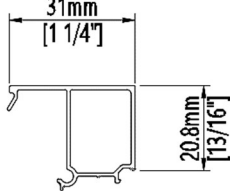
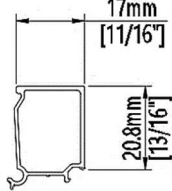
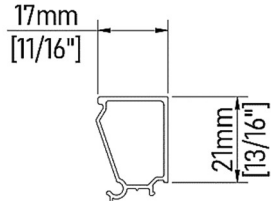
<p><b>WPGSX0001</b> – GLASS STOP (GSX) 6063-T5</p>	
<p><b>WPGSX0002</b> – GLASS STOP (GSX) 6063-T5</p>	
<p><b>WPGSX0003</b> – GLASS STOP (GSX) 6063-T5</p>	
<p><b>WPGSX0005</b> – GLASS STOP (GSX) 6063-T5</p>	



<b>GLAZING (INSULATED GLASS UNITS)</b> Tempered, Low-E, Argon Filled, Warm-Edge Spacer, 3A Molecular Sieve	
<b>GITPA0005 - TRIPLE PANE ASSEMBLE (TPA)</b>	<p>39mm [1 9/16"] 5mm [3/16"] 5mm [3/16"] 12mm [1/2"] 12mm [1/2"] 5mm [3/16"]</p>
<b>GIDPA0008 - DOUBLE PANE ASSEMBLE (DPA 8MM)</b>	<p>12mm [1/2"] 8mm [5/16"] 8mm [5/16"]</p>
<b>GIDPA0006 - DOUBLE PANE ASSEMBLE (DPA 5MM)</b>	<p>12mm [1/2"] 5mm [3/16"] 5mm [3/16"]</p>
<b>WAGSB0001 - GLASS SETTING BLOCK (GSB)</b> PVC	<p>50mm [1 15/16"] 3mm [1/8"] 3mm [1/8"]</p>





**ENERFREES**  
Window & Wall Systems

## TILT AND TURN WINDOW

**S-EF1070**

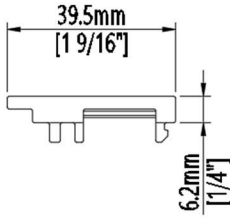
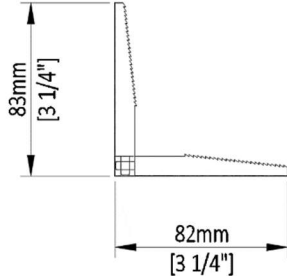
<p><b>WAGSB0002</b> - GLASS SETTING BLOCK (GSB) PVC</p>	
<p><b>WAGSB0002</b> - GLASS CORNER SETTING BLOCK (CSB) PVC</p>	

### SEALS

EPDM rubber is a high-density synthetic rubber used for outdoor applications and other spaces in need of tough, versatile parts.

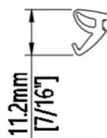
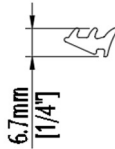
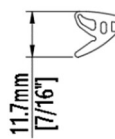
<p><b>WSIGX0001</b> - INTERIOR GASKET (IGX) EPDM RUBBER</p>	
<p><b>WSEGX0002</b> - EXTERIOR GASKET (EGX) EPDM RUBBER</p>	
<p><b>WSIGX0003</b> - INTERIOR GASKET (IGX) EPDM RUBBER</p>	



**ENERFREES**  
Window & Wall Systems

**TILT AND TURN WINDOW**

**S-EF1070**

<p><b>WSEGX0004</b> - EXTERIOR GASKET (EGX) EPDM RUBBER</p>	
<p><b>WSEGX0005</b> - EXTERIOR GASKET (EGX) EPDM RUBBER</p>	
<p><b>WSMFX0001</b> – MID-FRAME GASKET (MFG) EPDM RUBBER</p>	

**OTHER COMPONENT/S**

<p><b>WADXX0001</b> – EXTERIOR DRAIN COVER (DXX) PVC</p>	
<p><b>WAWBX0001</b> – WEATHER BAR (WBX) 6063-T5</p>	
<p><b>WPCKX0001</b> – CORNER JOINT KEY (CJK) STAINLESS STEEL</p>	



**ENERFREES**  
Window & Wall Systems

## TILT AND TURN WINDOW

## S-EF1070

<p><b>WPCJB0001</b> – CORNER JOINT BLOCK D-3/4" (CJB) 6063-T5</p>	
<p><b>WPCJB0002</b> – CORNER JOINT BLOCK D-1/2" (CJB) 6063-T5</p>	

<b>PERIMETER EXTENDERS</b>	
<p><b>PFE6X0001</b> – PF EXTENDER 6063-T5</p>	
<p><b>PFE6X0002</b> – PF EXTENDER 6063-T5</p>	



**ENERFREES**  
Window & Wall Systems

## TILT AND TURN WINDOW

## S-EF1070

<p>PFBMX0001 – PF BRICK MOULD 6063-T5</p>	<p>52mm [2 1/16"] 39mm [1 9/16"] 38mm [1 1/2"] 20mm [3/4"] 11mm [7/16"]</p>
<p>WFIFX0001 – INJECTED FOAM INSULATION (IFX)</p>	

### HARDWARE

<p>ONE-CLICK HANDLE E-HOC HANDLE</p>	
<p>FRICION HINGE E-FHTB</p>	<p>A, B, C, D, E, F, G, H, I 5mm [3/16"] 18mm [3/4"] 16mm [5/8"] 22mm [7/8"]</p>



**GENERAL SPECIFICATION**

I. PACKAGE INCLUDES

Manufacturing includes labour, materials, and services for the complete fabrication and assembly of ET&T1070 Tilt and Turn window system. Fabrication to include all necessary accessories and components, anchors, joint blocks, drain cover, seal rubbers, hardware, and sealants as required in the purchase agreement.

II. PACKAGE EXCLUDES

Structural installation or provision, framing, interior and exterior trims replacement/repairs, concrete masonry, brick restoration, final cleaning, protection, and/or any related work as specified.

III. PERFORMANCE AND QUALITY STANDARD REQUIREMENT AND ASSURANCE

Enerfree's EF1070 Tilt and Turn Window supplied to client under this specification must comply to the performance standard requirements and test report from an independent testing laboratory certifying compliance shall be given upon request by the owner/architect/contractor.

Test Required: AAMA/WDMA/CSA 101/I.S.2/A440-17 NAFS – North American Fenestration Standard / Specification for windows, doors and skylights and A440S1:19 Canadian Supplement to AAMA/WDMA/CSA 101/I.S.2/A440-17 NAFS - North American Fenestration Standard / Specification for windows, doors and skylights.

IV. MANUFACTURING REFERENCES

An approved shop drawing shall be provided for manufacturing reference and Enerfree's pricing. Enerfree's pricing and drawing shall be signed back to finalize manufacturing and fabricating details.

V. ALUMINUM EXTRUSION

All extruded aluminum sections shall be 6063-T5 alloy or equivalent.

VI. FASTENERS

Fasteners shall be stainless steel or as required.

VII. FABRICATION/MANUFACTURING

Window will be fabricated according to the approved shop drawings. All joints will be assembled tight using manufactures provided assembly machines to comply with quality standard and assurance to carry out the product design performance.



VIII. INSTALLATION

Enerfrees products that will be installed shall conform with the manufacturer's instructions and should comply with approved shop drawings. The work shall be performed by qualified or certified installer using proper equipment to carry out necessary, proper, and efficient installation in a professional manner.

IX. PROTECTION

Exposed aluminum finished surface shall be protected from contamination of mortar, concrete, paint, mud, soil, grease, sealant or caulking compound, and any other harmful substance that can cause damage to surface finish from prolong adhesion.

X. CLEANING

Provisional cleaning shall perform primary clear-out after installation and final cleaning shall be executed by the project owner in accordance with the general conditions listing methods outlined in AAMA 609 and 610-02.

**TILT AND TURN INTEGRATION TO FIXED WINDOW**

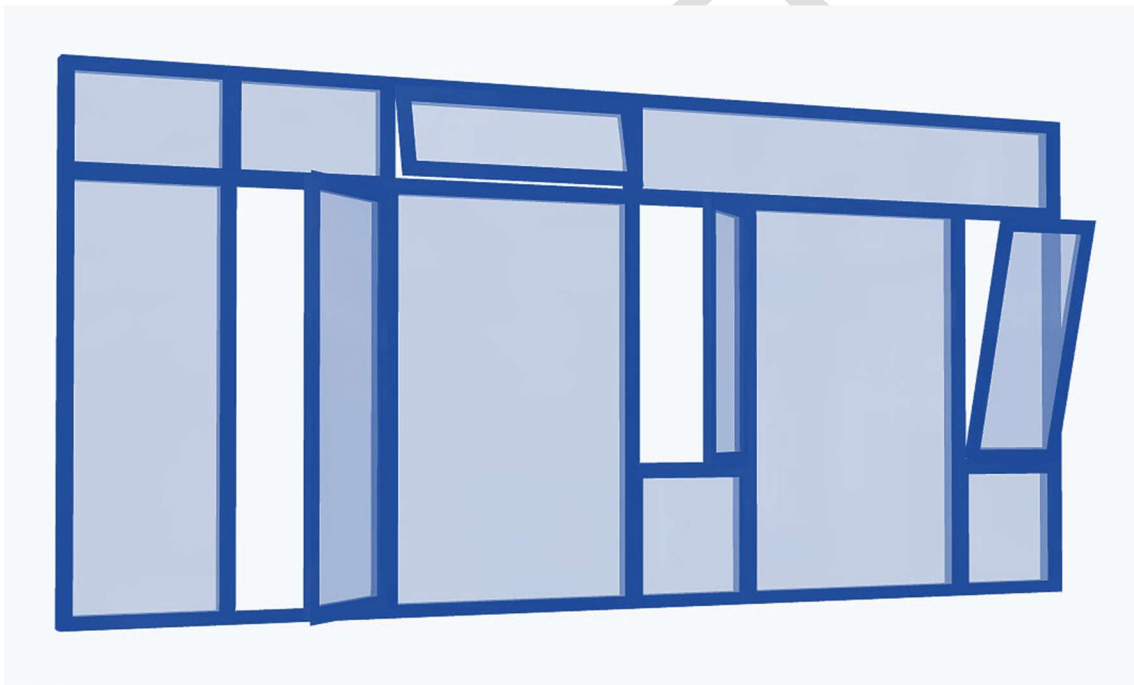

Enerfrees ET&T1070 is unlimited to integrate different operations and functionality to fixed window with custom sizes within the minimum/maximum width and height limits specified.